

Pancake type load cell



Features

Capacity 100t-1000t

High accuracy

High stability

Nickel plated alloy steel

Optional features

Stainless steel construction

DESCRIPTION

The ZML2 is big capacity pancake or spoke type compression load cell, capacity from 100t up to 1000t. The load cell is widely used in testing machine and weighing industrial. Due to reliable calibration machine, zhimin's large capacity load cell is always praised by our customers.

DIMENSIONS (mm)

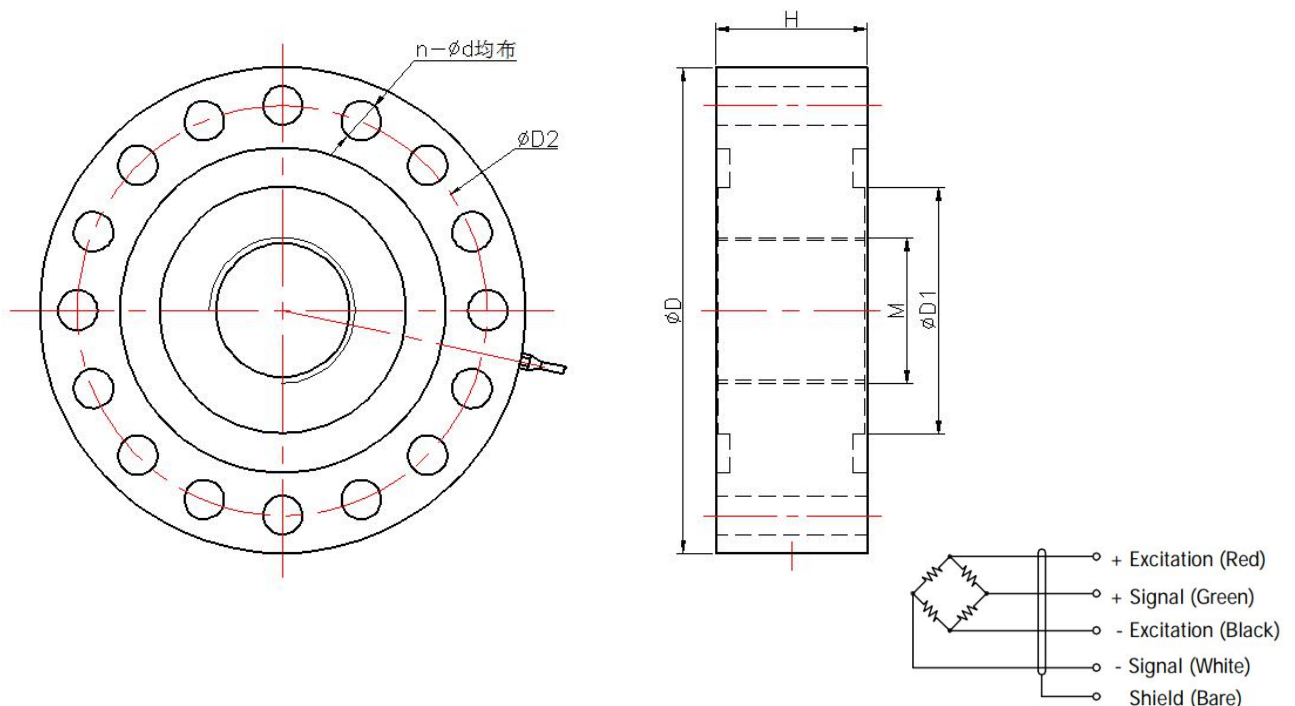

	M	D	D1	D2	H	n-Φd
100t	M96×4	320	162	270	100	16-Φ26
200-300t	M120×4	360	200	310	126	16-Φ32.5
500-1000t	M200×4	500	310	420	160	28-Φ27

SPECIFICATIONS

PARAMETER	VALUE	UNIT
Standard capacities (E _{max})	100-1000	T
Rated output-R.O.	2.0	mV/V
Zero balance	1	±% of rated output
Non linearity	0.2	±% of rated output
Hysteresis	0.1	±% of rated output
Non-repeatability	0.1	±% of rated output
Creep error (30 minutes)	0.03	±% of rated output
Zero return (30 minutes)	0.03	±% of rated output
Temperature effect on min. dead load output	0.0026	±% of rated output/°C
Temperature effect on sensitivity	0.0015	±% of rated output/°C
Compensated temperature range	-10 to +40	°C
Operating temperature range	-20 to +60	°C
Safe overload	150	% of R.C
Ultimate overload	200	% of R.C
Excitation, recommended	10	Vdc
Excitation, maximum	15	Vdc
Input resistance	720±10	Ohms
Output resistance	700±3	Ohms
Insulation resistance	5000	Mega-Ohms
Material	Alloy steel	
Protection class	IP66	

All specifications listed subject to change without notice.